

Patent Pending Trampoline Leveling System Information and Installation Instructions

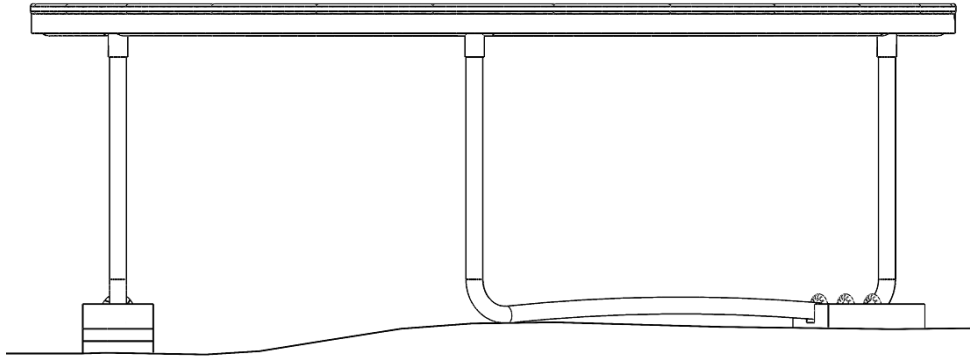

Triple action Boot Blocks with U-Rebar Stakes help level, anchor, and stabilize your trampoline. Boot and Leveling Blocks can accept up to 3 U-Rebar Stakes. Up to four Leveling Blocks can be stacked under Boot Block to adjust for uneven ground.



WARNING: Trampoline must be properly leveled and anchored prior to jumping. Use trampoline only with mature, knowledgeable supervision.

DO NOT attempt or allow somersaults. Landing on the head or neck can cause serious injury, paralysis, or death, even when landing in the middle of the trampoline.

DO NOT allow more than one person on the trampoline. Use by more than one person at the same time can result in serious injury.

Please read and understand the safety instructions provided with your trampoline. Trampoline must be properly assembled prior to installing Boot Blocks or Boot with Leveling Block(s). Assure that Boot Block fits the trampoline leg correctly. Blocks are available in two sizes: 1-1/4" chamber size fits the most common tube size, 1-5/8" chamber size fits heavy duty trampolines with larger diameter tube.

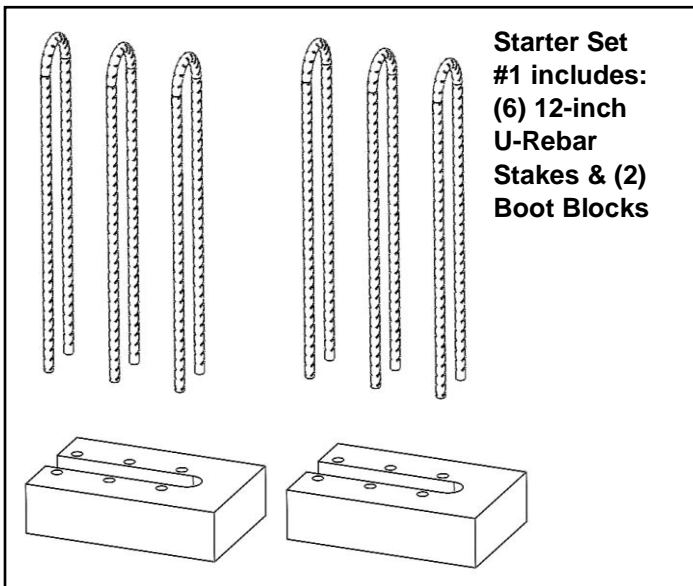

**Starter Set #1 includes:
(6) 12-inch U-Rebar Stakes & (2) Boot Blocks**

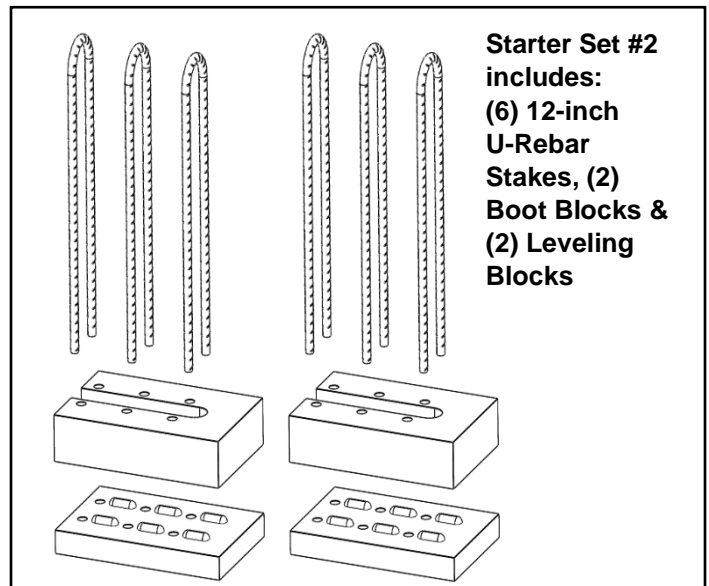

**Starter Set #2 includes:
(6) 12-inch U-Rebar Stakes, (2) Boot Blocks & (2) Leveling Blocks**

Both sets available for 1 1/4" diameter tube or 1 5/8" diameter tube.

Also sold individually:

- Boot Block for 1-1/4" tube - 9" x 6" x 2"
- Boot Block for 1-5/8" tube - 9" x 6" x 2 1/4"
- Standard U-Rebar Stake - 12" x 2" x 3/8"
- Heavy Duty U-Rebar Stake - 16" x 2" x 3/8"
- Leveling Pads - 9" x 6" x 1"

Installation Instructions and Diagrams

Place your trampoline in a level and obstacle free location with a surrounding safety zone. To level and secure trampoline, install Boot Blocks at base of legs. Boot Blocks will raise each leg by ½ inch. On uneven ground, further leveling of the trampoline can be achieved by adding Leveling Blocks under the Boot Blocks. Specially designed interlocking nubs will allow you to correctly position and stack the blocks. Each Leveling Block will raise the leg another inch. The stack limit is four Leveling Blocks per Boot Block. Purchase and install longer Heavy Duty U-Rebar Stakes to secure stacks with more than two Leveling Blocks. Once trampoline is leveled, use a hammer, drive stakes through holes into the ground. With time and use, periodically check the installation to assure that the trampoline is secure and level.

Boot Block Installation

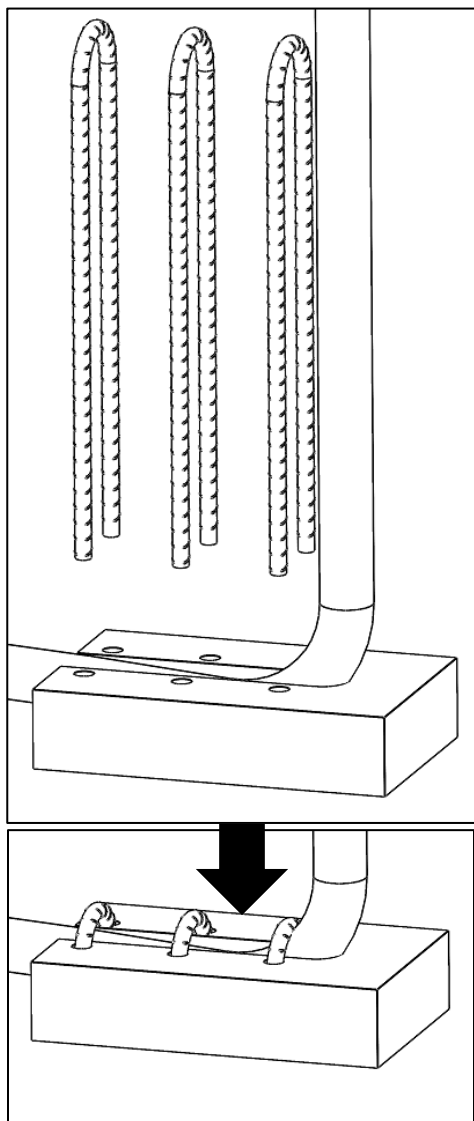

Boot & Leveling Block Installation

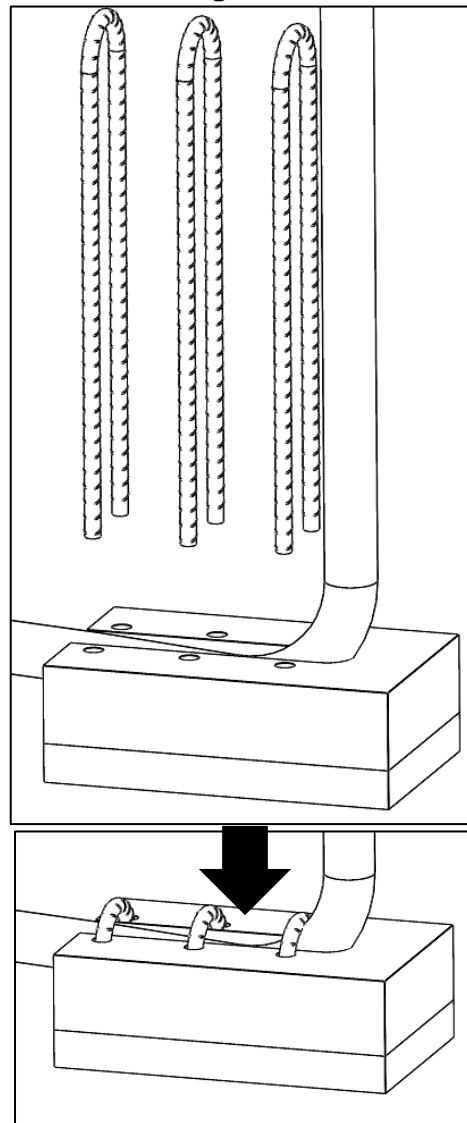

For more information, please contact us at:

info@leveldry.com or go to

<https://leveldry.com>

Level Dry, PO Box 580 Martinsville, NJ 08836

Patent pending, international patents to be filed.

**Do not exceed
four Leveling
Blocks, must
use Heavy Duty
U-Rebar Stake.**

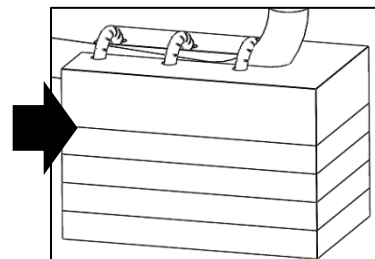

This product is for residential installations, not for commercial use. Proper installation, periodic maintenance and safe use are the sole responsibility of the homeowner and user. Just leveling and staking the trampoline on one side may not be sufficient in securing trampoline in high wind areas. Seek reliable advice to assure adequate staking. Company will not be liable for any direct, indirect, punitive, incidental, special consequential damages, to property or life, whatsoever arising out of or connected with the use or misuse of Level Dry products.